



# INSTRUCTION BULLETIN

No.9004948  
Machine: S30 XP/  
S30 X4  
Published: 07-2008  
Rev. 00

**NOTE: DO NOT DISCARD the Parts List from the Instruction Bulletin. Place the Parts List in the appropriate place in the machine manual for future reference. Retaining the Parts List will make it easier to reorder individual parts and will save the cost of ordering an entire kit.**

*NOTE: Numbers in parenthesis ( ) are reference numbers for parts listed in Bill of Materials.*

Installation instructions for **kit number 9004070**

## SYNOPSIS:

This kit contains the parts needed to install a left side brush on S30 XP and S30 X4 sweepers. Please follow step-by-step instructions.

## SPECIAL TOOLS / CONSIDERATIONS: NONE

(Estimated time to complete: 4 hours)

## When assembling/disassembling hydraulic components:

1. Thoroughly clean outside of hydraulic components **before** disconnecting hydraulic hoses or fittings to prevent contaminants from entering system.
2. Cap disconnected hoses and open ports to prevent contaminants from entering system.
3. Flush hoses and fittings with air, solvent, or hydraulic fluid to prevent contaminants from entering system.
4. Mark hydraulic hoses with locations of where they are attached. Markings make it easier to reconnect hoses to proper locations.
5. Discard hydraulic fluid drained from the system. Use only new approved hydraulic fluid to replenish hydraulic reservoir. Obey all federal, state, and local laws/regulations governing the disposal of environmentally hazardous materials when discarding hydraulic fluid.

## PREPARATION:

1. Park the machine on a clean level surface.
2. Raise the hopper, engage the hopper support bar, and lower the hopper to lower the hopper support bar onto the bracket.



**WARNING: Lift arm pinch point. Stay clear of hopper lift arms.**



**WARNING: Raised hopper may fall. Engage hopper support bar.**

3. Turn off the machine, engage the parking brake, and remove the key.

**FOR SAFETY: Before leaving or servicing machine, stop on level surface, turn off machine, and remove key.**

4. Open the top cover, side shroud, and front shroud.

## INSTALLATION:

1. Apply lubricant onto the o-rings of the two straight fittings (37) and thread the fittings into the brush motor (10). Refer to Fig. 1.

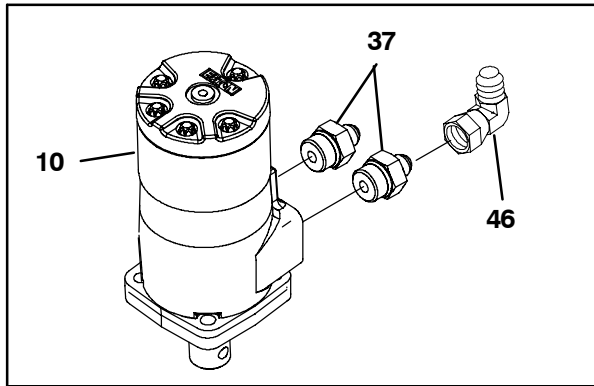

FIG. 1

2. Thread a 90° fitting onto one straight fitting (37) installed on the brush motor (10). Refer to Fig. 1.

3. Use a clevis pin (5) and a cotter pin (33) to install the side brush arm (2) onto the side brush motor mounting bracket (1). Refer to Fig. 2.
4. Use a hex screw (26), a sleeve (29), two flat washers (27), and a hex nut (28) to install the side brush linkage arm (3) onto the side brush motor mounting bracket (1). Refer to Fig. 2.
5. Use a roll pin (22) to install the threaded rod (23) into the knob (21). Refer to Fig. 2.
6. Use the knob assembly assembled in the previous step to install the steel angle (20) and spring (19) onto the side brush pivot (4). Refer to Fig. 2.
7. Use a clevis pin (5) and cotter pin (33) to install the side brush pivot (4) onto the side brush arm (2) and a clevis pin (6) and cotter pin (33) to install the side brush pivot onto the side brush linkage arm (3). Refer to Fig. 2.
8. Press a sleeve bushing (14) into the steel tube (13). Refer to Fig. 2.

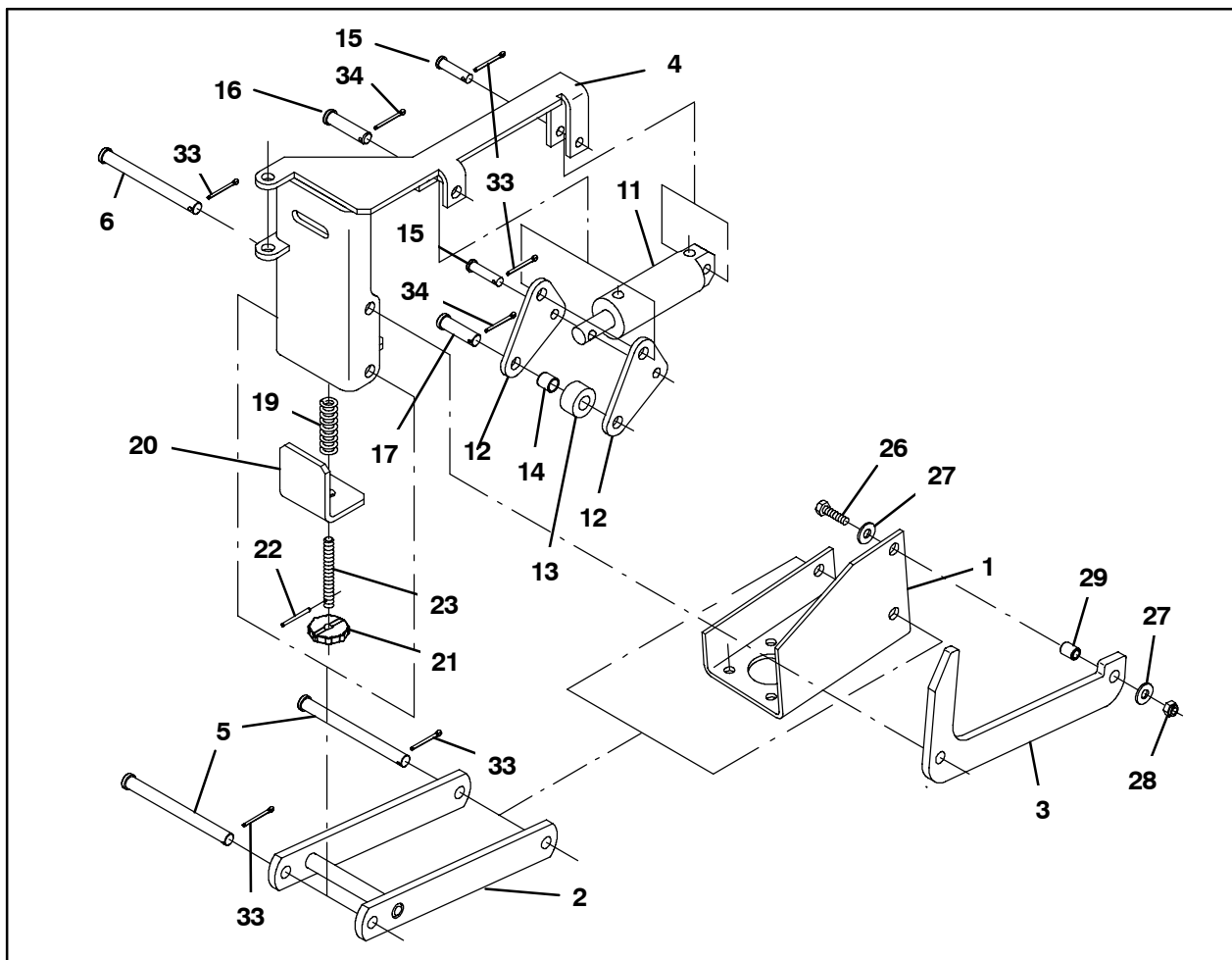
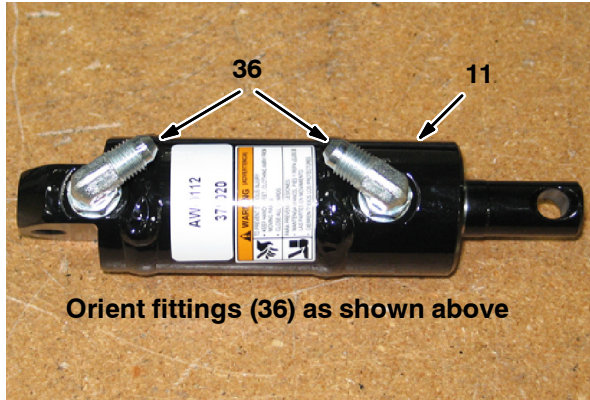

FIG. 2

9. Use a clevis pin (17) and cotter pin (34) to assemble the steel tube (13) onto the two brush lift levers (12). Refer to Fig. 2
10. Use a clevis pin (16) and cotter pin (34) to install the brush lift levers (12) onto the side brush pivot (4). Refer to Fig. 2.
11. Install two 90° fittings (36) onto the hydraulic cylinder (11). Fittings must be oriented as shown in Fig. 3.



**FIG. 3**

12. Use a clevis pin (15) and cotter pin (33) to install the hydraulic cylinder (11) onto the side brush pivot (4) and a clevis pin (15) and cotter pin (33) to install the hydraulic cylinder onto the brush lift levers (12). Refer to Fig. 2.

13. Use four hex screws (9) and four flat washers (25) to install the motor string guard (7) and brush guard (8) onto the side brush motor bracket (1) and brush motor (10). Refer to Fig. 4.

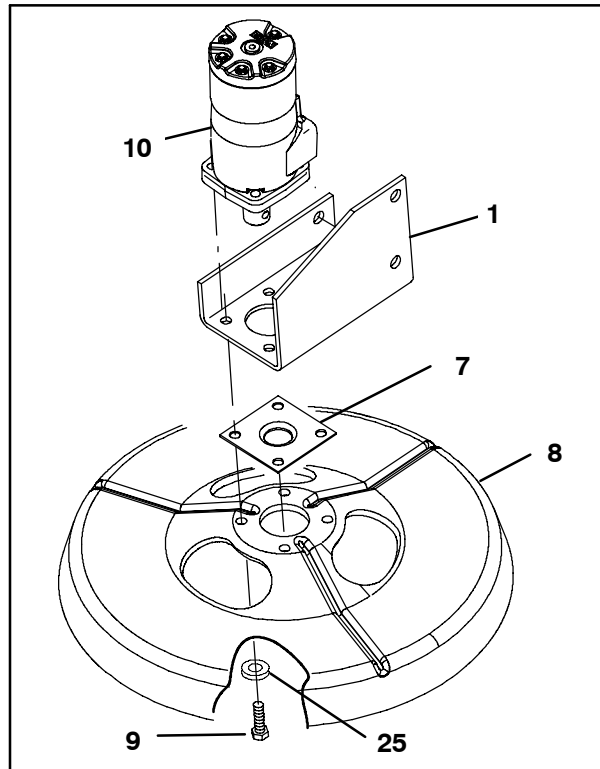

**FIG. 4**

14. Use a clevis pin (35) and cotter pin (33) to install the left brush assembly onto the front bumper. Refer to Fig. 5.

15. Use a hex screw (24) and a flat washer (25) to install the 2.5" spring (18) onto the frame of the machine. Refer to Fig. 5.

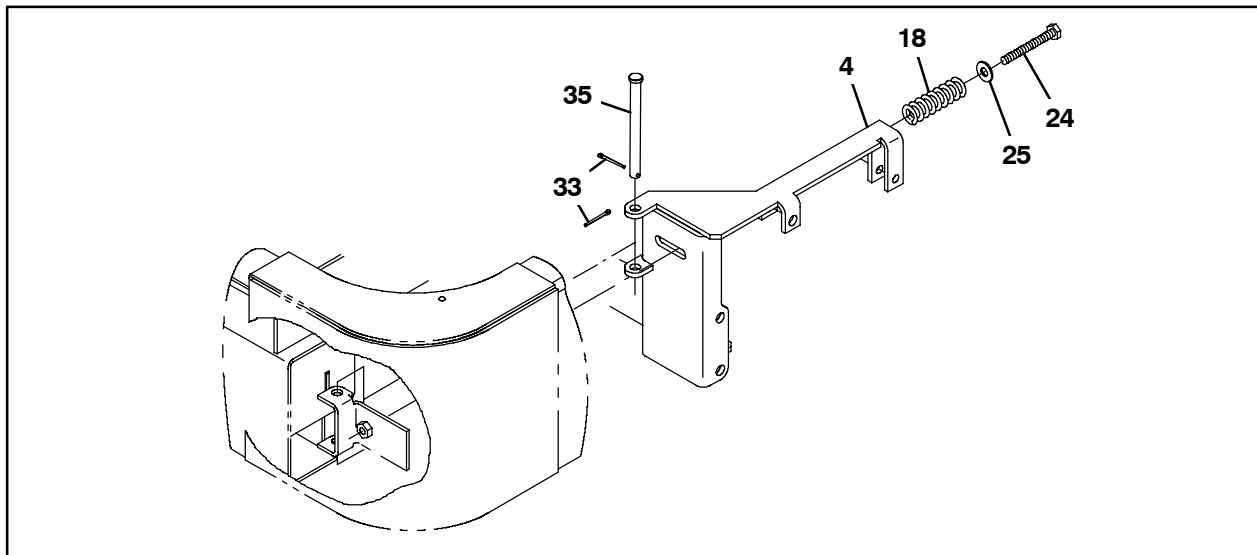

**FIG. 5**

16. Cut any cable ties securing the 134" hose connected to the right side brush to the machine. Refer to Fig. 6.
17. Disconnect the 134" hose from the right side brush motor and the steering drain tube. Discard the removed hose. Refer to Fig. 6.

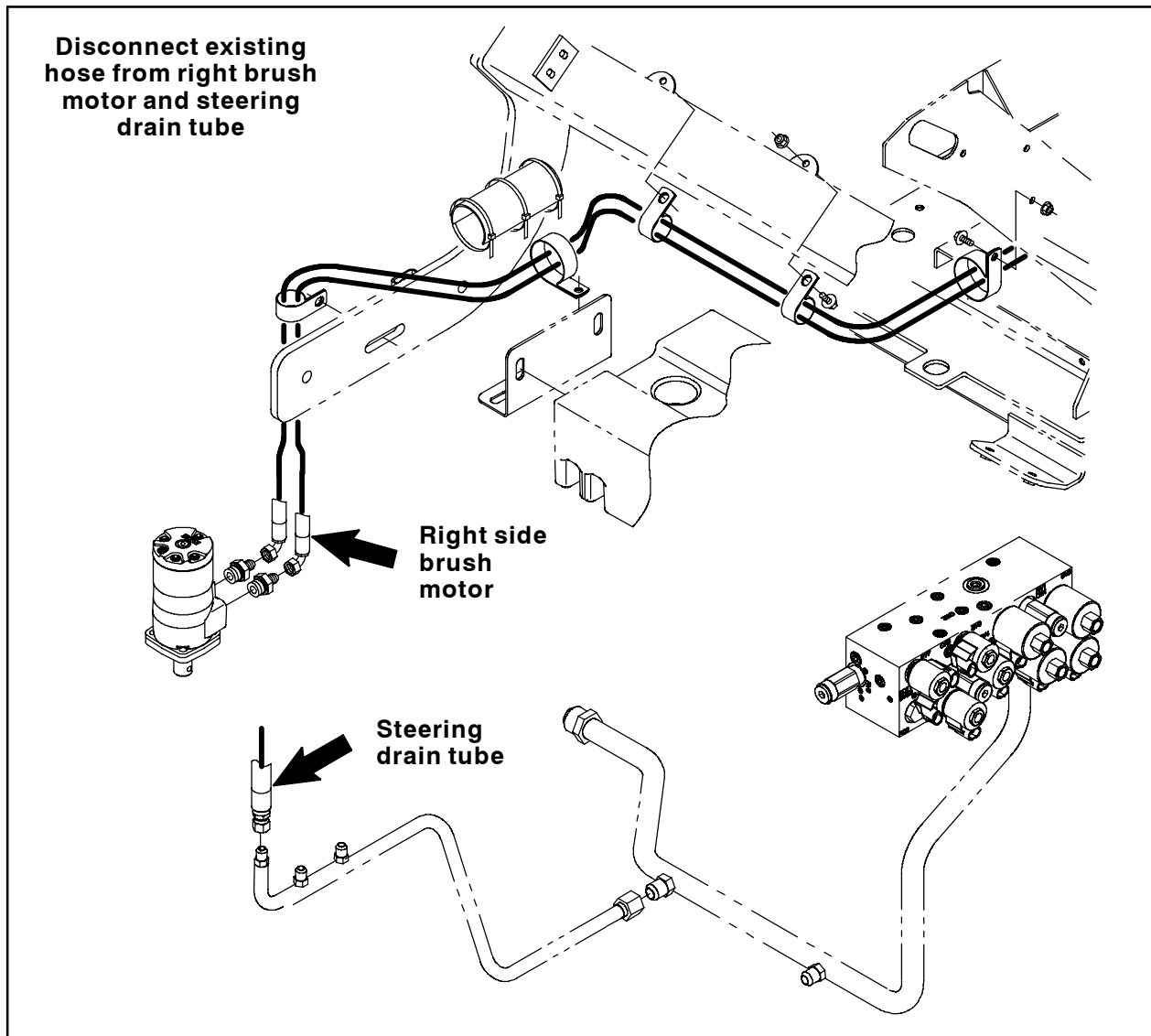
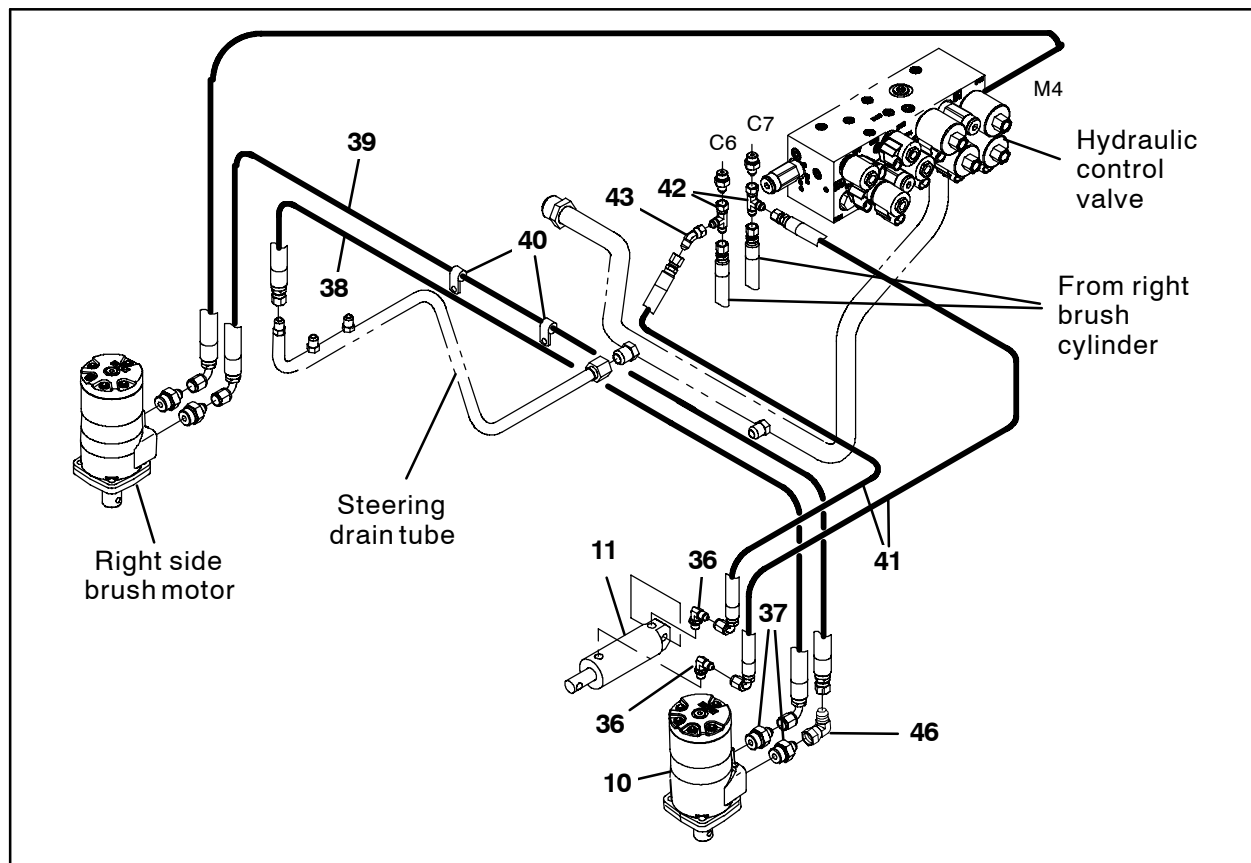

**FIG. 6**

*NOTE: Refer to Fig. 7 locations of hydraulic components and fittings and routing hydraulic hoses in Step 18 through Step 28.*

18. Connect the 120" hose (39) to the port on the right side brush motor where the 134" hose was previously installed.
19. Route the 120" hose (39), to the left side brush, and connect the hose to the left side brush.
20. Connect the 102" hose (38) to the left side brush and route the hose to the steering drain tube.
21. Connect the 102" hose (38) to the location where the 86" hose was previously located.
22. Disconnect the right brush cylinder hoses from ports C6 and C7 on the hydraulic control valve.

23. Install a 45° fitting (43) onto one t-fitting (42).
24. Install the t-fitting (42) with the 45° fitting (42) into port C6 and the remaining t-fitting (42) into port C7 the hydraulic control valve.
25. Connect a 126" hose (41) to the fittings installed into ports C6 and C7 of the hydraulic control valve in the previous step.
26. Route the both 126" hoses (41) connected to the hydraulic control valve to the hydraulic cylinder and attach the hoses to the cylinder.
27. Reinstall the right side brush hoses removed from ports C6 and C7 on the hydraulic control valve to the appropriate ports.
28. Use the two keeper clips (40) to secure the 120" hose (39) to the hopper.



**FIG. 7**

29. Install the two clamps (44) onto hydraulic hoses (38) and (39) coming from the left side brush and use existing hardware on the hopper lift arm to install the two clamps (44) onto the left arm of the hopper lift arm. Refer to Fig. 8.

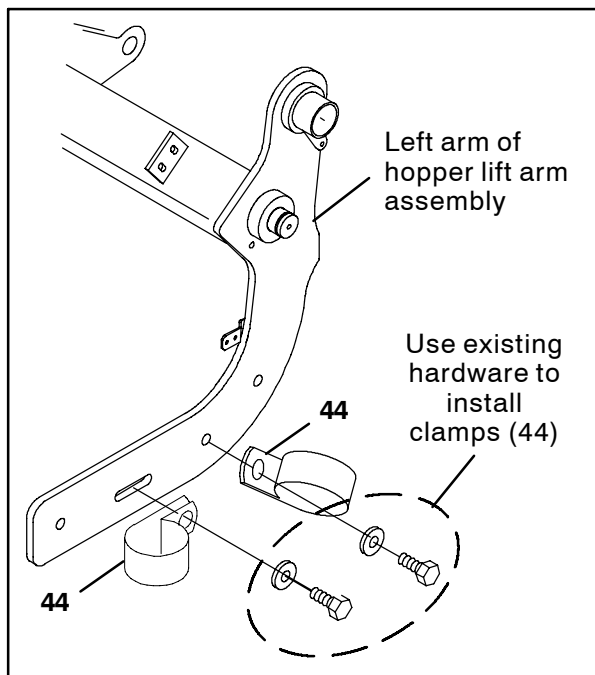

FIG. 8

30. Use cable ties (45) to secure the hydraulic hoses away from moving parts.
31. Add hydraulic fluid to the hydraulic system. Refer to the Maintenance section of the Operators Manual for the procedure how to add hydraulic fluid to the hydraulic system.
32. Use four hex wood screws (31) to install the hub (30) onto the brush. Refer to Fig. 8.
33. Use the side brush clip (32) to install the brush onto the left side brush assembly. Refer to Fig. 8.
34. Start and test the machine. Operate the side brushes. Inspect newly installed hoses, fittings, and components for leaks. Raise and lower the hopper and check hoses to ensure they are not catching on moving parts or stretching tight.

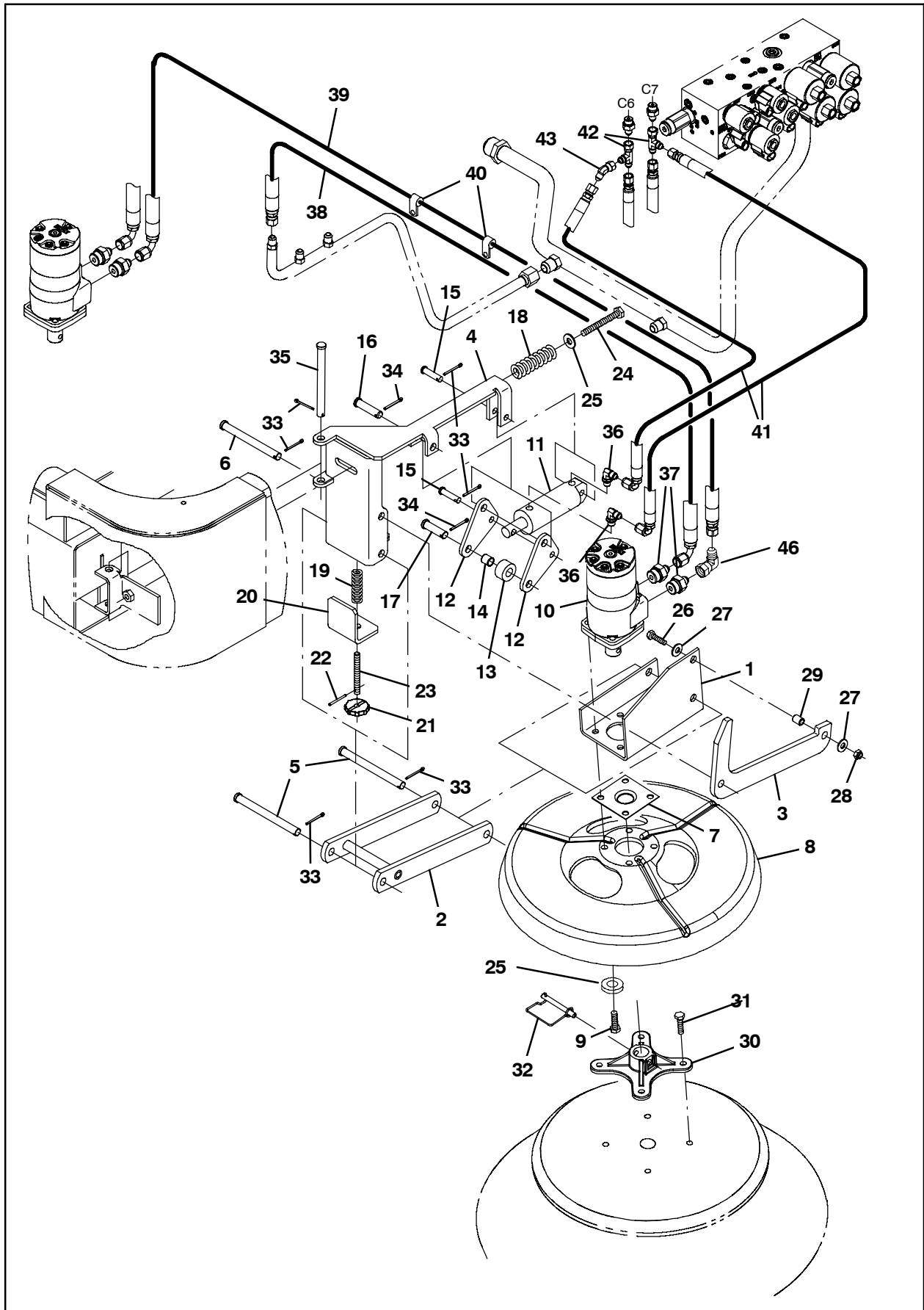

FIG. 9

**Bill of Materials for Side Brush Kit, LH, CI [S30] - 9004070**

<b>Ref.</b>	<b>Part No.</b>	<b>Description</b>	<b>Qty.</b>
▽	9004070	Side Brush Kit, LH, CI [S30]	1
▲	1 1031916	Bracket, Mtg, Motor, Side Brush	1
▲	2 1029682	Arm Wldt, Brush, Side	1
▲	3 1026459	Arm, Linkage, Side Brush	1
▲	4 1039649	Pivot Wldt, Brush, Side	1
▲	5 51225	Pin, Clevis, 0.50d X 5.50l	2
▲	6 51538	Pin, Clevis, 0.50d X 5.00l	1
▲	7 16082	Guard, String, Motor, Brush	1
▲	8 53984	Guard, Brush	1
▲	9 46559	Screw, Hex, .38-16 X 1.25, NI	4
▲	10 379607	Motor, Hyd, Gear, Int 17.9 Bi-Dir 1500	1
▲	11 1041034	Cylinder, Hyd, 1.5b 06.3l 01.50strk 2500	1
▲	12 1026462	Lever, Lift, Brush	2
▲	13 1026525	Tube, 0.59id 1.25od 00.6l, Stl	1
▲	14 59634	Bushing, Sleeve, 0.50b 0.59d 0.62l, Fgl	1
▲	15 29558	Pin, Clevis, 0.37d X 1.50l	2
▲	16 51534	Pin, Clevis, 0.50d X 2.00l	1
▲	17 43290	Pin, Clevis, 0.50d X 1.75l	1
▲	18 45261	Spring, Cmpr, 0.97od .11wir 02.5l	1
▲	19 22290	Spring, Cmpr, 0.72od .06wir 02.3l	1
▲	20 1036333	Angle	1
▲	21 1039141	Knob	1
▲	22 13865	Pin, Roll, .125d X 1.25l, .125/.129	1
▲	23 1039199	Rod, Thr, M10x1.5 80l	1
▲	24 06965	Screw, Hex, M10 X 1.5 X 80, 8.8	1
▲	25 32492	Washer, Flat, 0.38, Std	5
▲	26 76570	Screw, Hex, M8 X 1.25 X 30, 8.8	1
▲	27 32491	Washer, Flat, 0.31, Std	2
▲	28 08709	Nut, Hex, Lock, M8 X 1.25, NI	1
▲	29 80395	Sleeve, P/M, 0.31b 0.50d 0.7l [430ss]	1
▲	30 47501	Hub, Adapter, Brush, 1.00b	1
▲	31 39394	Screw, Hex, .31-09 X 1.25, Wood	4
▲	32 84581	Pin Assy, Side Brush W/ Clip	1
▲	33 08182	Pin, Cotter, .125 X 1.00	6
▲	34 39005	Pin, Cotter, .094 X 0.75	2
▲	35 222196	Pin, Clevis, 0.50d X 4.25l	1
▲	36 77097	Fitting, Hyd, E90, Jm04/Om04	2
▲	37 47508	Fitting, Hyd, Str, Jm06/Om10	2
▲	38 396217	Hose, Hyd, Tc06, Jf06e90/Jf06str, 102.0	1
▲	39 1043049	Hose, Hyd, Tc08, Jf06e90/Jf06str, 120.0	1
▲	40 30407	Clip, Keeper, Open	2
▲	41 1036201	Hose, Hyd, Tc04, Jf04e90/Jf04str, 126.0	2
▲	42 57988	Fitting, Hyd, Tee, Jf04/Jm04/Jm04, Run	2
▲	43 68441	Fitting, Hyd, E45, Jf04/Jm04	1
▲	44 53468	Clamp, Cable, Stl, 1.75d X 1.00w, 1 Hole	2
▲	45 44961	Tie, Cable, Nyl, 14.5L .30W 4.0 Max D	10
▲	46 47504	Fitting, Hyd, E90, Jf06/Jm06	1

TENNANT COMPANY  
P. O. Box 1452  
Minneapolis, MN 55440-1452